

# RK-2910

## Carbon-brush motors

Application : Car Trunk Lifting Device

用途：汽車後尾門推杆

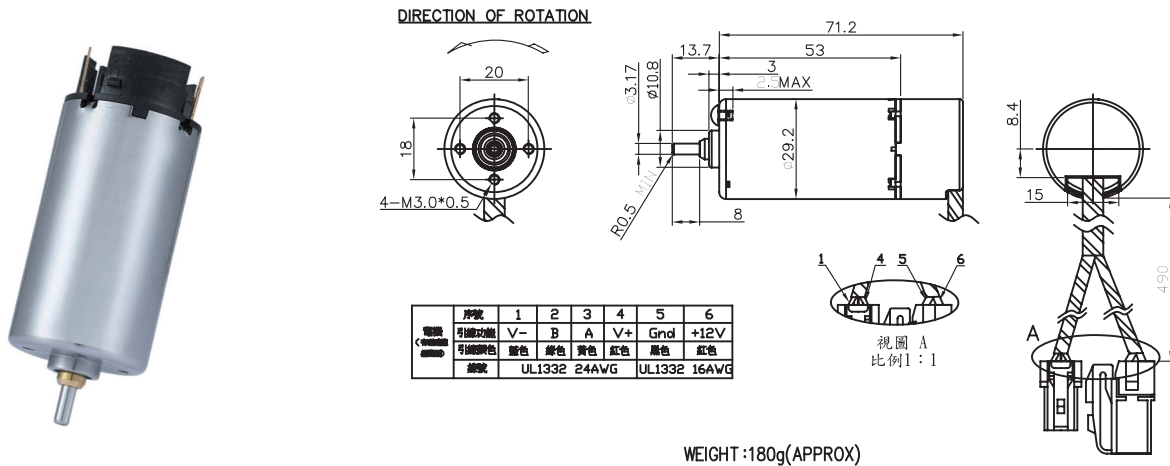

MODEL	VOLTAGE		NO LOAD		AT MAXIMUM EFFICIENCY					STALL			
	OPERATING RANGE	NOMNAL	SPEED	CURRENT	SPEED	CURRENT	TORQUE	OUTPUT	EFF	CURRENT	TORQUE		
			rpm	mA	rpm	A	Kg-cm	mN-m	W	%	A	Kg-cm	mN-m
RK-2910VB-2832S-R-CE-IE	10.0 - 14.0	12.0V CONSTANT	6600	700	5800	3.80	0.53	52	30	70	20	3.2	313

馬達的出軸長度及性能參數，EMC 對策可依客人要求做調整，詳情可詢問相關業務人員。  
Please inquire your sales representative for output, performance and EMC solution.

