

BL50E20B

Brushless Dc Motor

Application : Robot Vacuum

用途：智能吸尘器

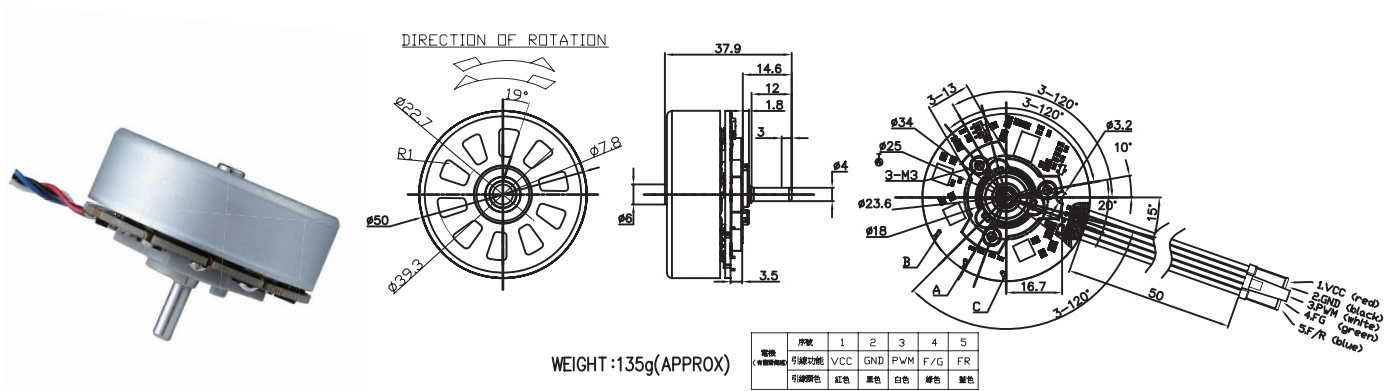

MODEL	VOLTAGE		NO LOAD		AT MAXIMUM EFFICIENCY					STALL			
	OPERATING RANGE	NOMINAL	SPEED rpm	CURRENT A	SPEED rpm	CURRENT A	TORQUE g-cm	TORQUE mN-m	OUTPUT W	EFF %	CURRENT A	TORQUE g-cm	TORQUE mN-m
BL50E20B-20V2.8K12W-C1Y0V	20V-28V	20.0V CONSTANT	2800	0.20	2173	1.12	575	56.35	12.83	70.1	4.05	2640	258.8
BL50E20B-28V4K17W-C1Y0V	20V-28V	28.0V CONSTANT	4900	0.18	4005	1.56	589	57.75	24.22	85	7.90	3030	297.1

马达的出轴长度及性能参数，EMC 对策可依客人要求做调整，详情可询问相关业务人员。
Please inquire your sales representative for output, performance and EMC solution.

